

SMART[®]



Service Parts Diagrams

**For Model:
FSE-510-W**

Service Parts Diagrams Revision History

Revision 1 - July, 2024

- New document

First Customer Ship: April, 2024

Service Parts

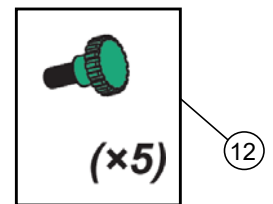
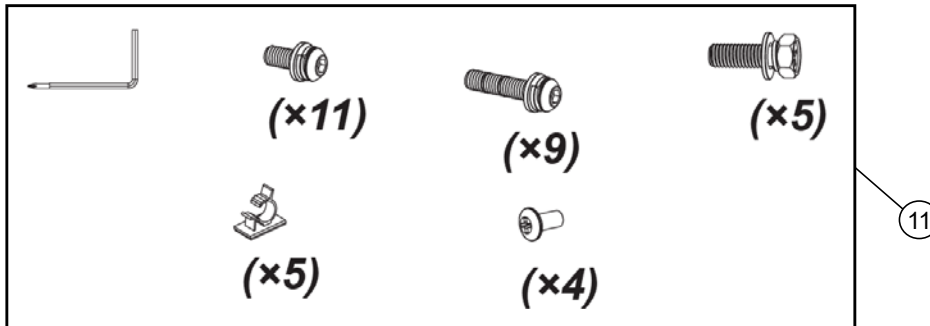
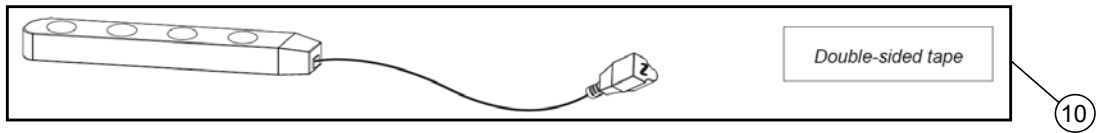
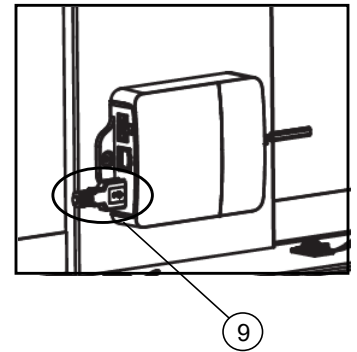
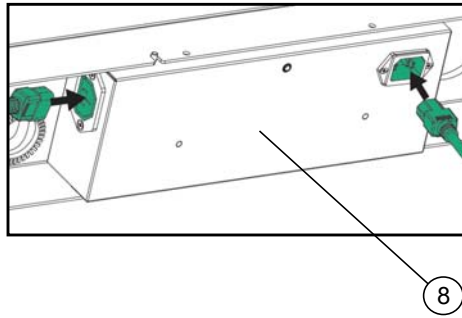
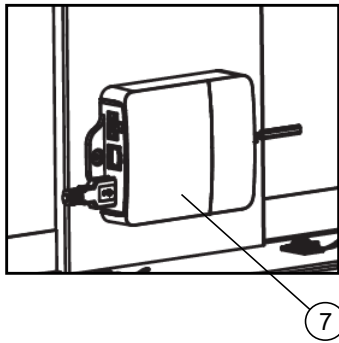
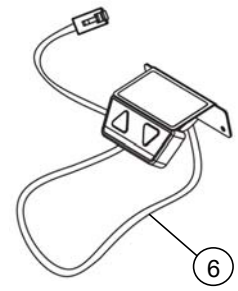
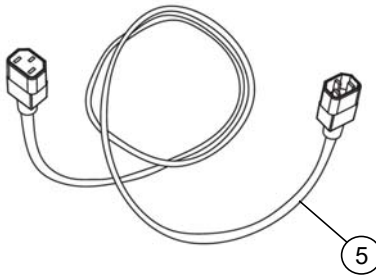
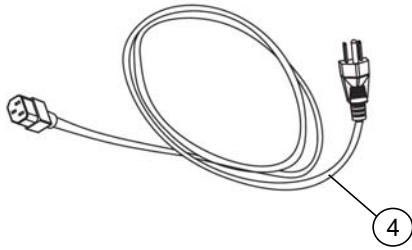
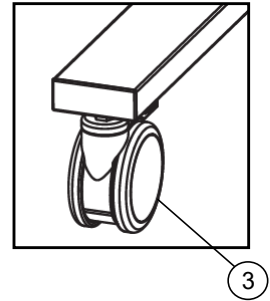
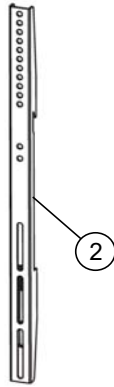
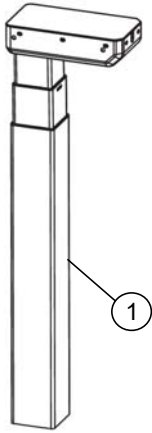

Item	Part No.	Qty	Description
1	1041620	2	Actuator, 65 cm, SMART Electric Stand, FSE-500, FSE-510 & WSE-500, White
2	1041623	2	Vertical Mounting Bracket, VESA, FSE-5X0 & WSE-500
3	1041624	4	Castor, 100 mm Black, SMART Floor Stand Electric FSE-5X0
4	1022063	1	Cable, power, North America, 8' (2.4 m)
4	93-055	1	Cable, power, United Kingdom, 8' (2.4 m)
4	93-056	1	Cable, power, Australia, 8' (2.4 m)
4	93-054	1	Cable, power, Europe, 8' (2.4 m)
4	93-00708-20	1	Cable, power, China, 8' (2.4 m)
4	93-00654-20	1	Cable, power, Japan, 8' (2.4 m)
4	93-063	1	Cable, power, South Africa, 8' (2.4 m)
4	1018969	1	Cable, power, Singapore, 14' 9" (4.5 m)
4	1018970	1	Cable, power, India, 14' 9" (4.5 m)
4	1018971	1	Cable, power, Saudi Arabia, 14' 9" (4.5 m)
4	1018972	1	Cable, power, Brazil, 14' 9" (4.5 m)
4	1025597	1	Cable, power, Argentina, 14' 9" (4.5 m)
4	1025603	1	Cable, power, Chile and Italy, 14' 9" (4.5 m)
4	1030859	1	Cable, power, Korea, 8' (2.4 m)
5	1040594	1	Cable, IEC 60320-C14 & C13 Connectors, 1 m, FSE-5X0, WSE-500 - NA
5	1041463	1	Cable, IEC 60320-C14 & C13 Connectors, 1 m, FSE-5X0, WSE-500 - EU/UK
6	1041618	1	Remote control, SMART Electric Stands FSE-5X0 & WSE-500
7	1041617	1	Main Controller, SMART Electric Stands, FSE-510
8	1041627	1	Power Supply, SMART Electric Stands FSE-5X0 & WSE-500
9	1041619	1	Cable, USB A Male - A Male, 2 m, FSE-5X0, WSE-500
10	1040700	1	Assembly, Power Strip, UL, 4 Outlet, 90-130Vac, 15A, 15', Surge Protected - NA
10	1040698	1	Assembly, Power Strip, CE, 4 Outlet, 220-250Vac, 16A, 10' - EU
10	1033107	1	Power Bar, 6 Outlet UK, Surge Protection, 5 m
11	1041630	1	Kit, Hardware, FSE-5X0
12	1041629	1	Thumb Screws, Set of 5, FSE-5X0